

YONG YUAN VALVE

FORGED STEEL GATE VALVE

YSG SERIES

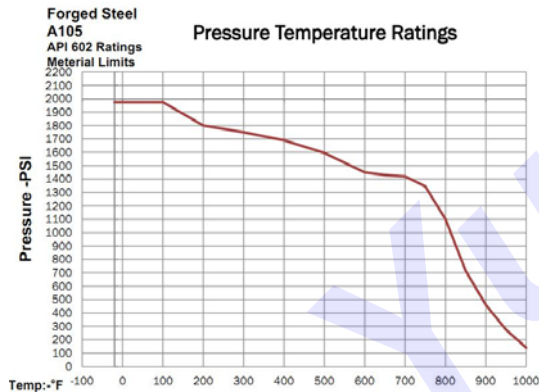
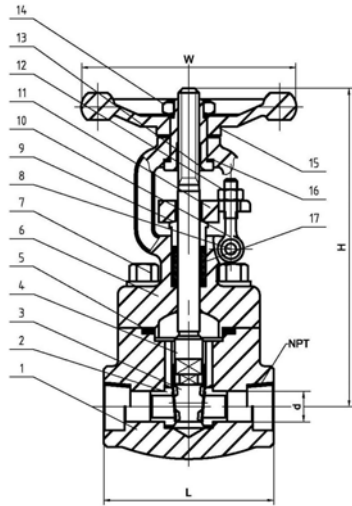

Features:

- Conventional Port
- Design and Manufacture: API 602
- Threaded ends to ANSI B1.20.1(NPT)
- Socket-weld dimension: ASME B16.11
- Pressure-temperature ratings: ASME B16.34
- Inspection and Test: API 598
- NACE MR-01-75

Parts & Materials

No.	Part	Material
1	BODY	ASTM A105
2	SEAT RING	A276-410+Stainless Steel
3	Disc	Stainless Steel A276-420
4	STEM	Stainless Steel A276-410
5	BODY GASKET	SS304+Graphite
6	CAP	ASTM A105
7	BOLT	Carbon Steel A193-B7
8	Gland bolt pin	Stainless Steel A276-410
9	Gland	Stainless Steel A276-410
10	Eyelet Bolt	Carbon Steel A193-B7
11	Gland flange	Carbon Steel WCB
12	Gland bolt nut	Carbon Steel A194-2H
13	Stem nut	Stainless Steel A439-D2
14	Handwheel nut	Carbon Steel A108-1020
15	Handwheel	DUCTILE IRON
16	Sleeve Washer	Stainless Steel A276-410
17	Packing	Graphite

Dimensions(in)

NPS	PART#	L	d	H	W	NPT	Weight (lbs)
1/4(FP)	YSG02A8	3.11	0.31	6.34	3.94	1/4	4.89
3/8(FP)	YSG03A8	3.11	0.41	6.34	3.94	3/8	4.85
1/2	YSG04A8	3.11	0.41	6.34	3.94	1/2	4.85
3/4	YSG05A8	3.62	0.53	6.42	3.94	3/4	5.29
1	YSG06A8	4.37	0.71	7.72	4.92	1	9.37
1-1/4	YSG07A8	4.72	0.94	8.78	6.30	1-1/4	12.57
1-1/2	YSG08A8	4.72	1.14	9.88	6.30	1-1/2	15.54
2	YSG09A8	5.51	1.44	11.42	7.09	2	24.03
2-1/2	YSG10A8	7.01	1.77	13.11	7.87	2-1/2	33.29

TEL:0086-579-8715288
E-mail:cnyvc@cnyvc.com

0086-579-8725688
yu@cnyvc.com

FAX:0086-579-87151442
HTTP:www.oil-fieldvalve.com