

# YONG YUAN VALVE

## STAINLESS STEEL FLOATING BALL VALVE

SERIES: AQ41F-10KP



### SPECIFICATIONS:

- DESIGN AND MANUFACTURE (FULL PORT)
- FACE TO FACE:JIS B2002 Series 6
- FLANGE:JIS B2220
- PRESSURE TEST:JIS B2003
- DESIGN AND MANUFACTURE OF PRODUCTS COMPLY WITH THE PROVISIONS OF THE ASME B16.34

### SPECIFICATIONS

NOMINAL PRESSURE	10K
SHELL STRENGTH (WATER)	2.06 Mpa
SEALING TEST (WATER)	1.51 Mpa
AIR SEAT PING (AIR)	0.6 Mpa

### Parts & Materials

No.	Part	Material
1	BODY	SCS13/SCS14
2	STUD BOLT	304
3	NUT	304
4	BONNET	SCS13/SCS14
5	SPIRAL WOUND	PTFE
6	SEAT	PTFE
7	BALL	SUS304/SUS316
8	STEM	SUS304/SUS316
9	STEM GASKET	PTFE
10	PACKING	PTFE
11	PACKING	PTFE
12	PACKING	PTFE
13	GLAND	SUS304/SUS316
14	NUT	304
15	HEX BOLT	304
16	LOCATOR CARD	304
17	FLEXIBLE WASHER	304
18	HEX BOLT	304
19	HANDLE	QT400-18

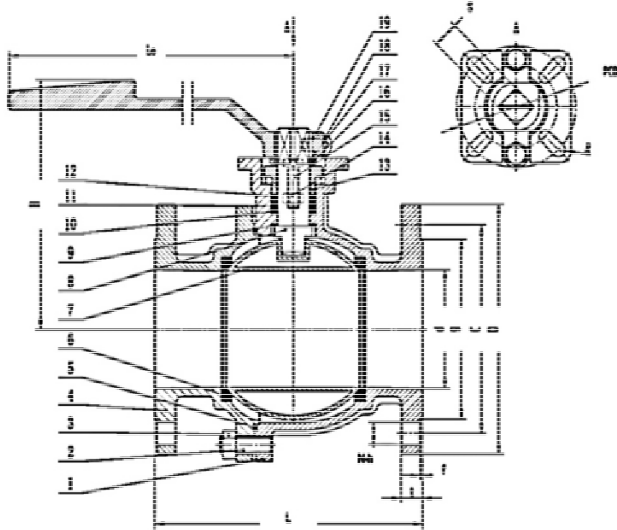

### DIMENSIONS(mm)

DN	L	D	C	g	d	N	h	t	f	H	PCD	R	S	L0
25	127	125	90	69	25	4	19	14	1	96.5	50	7	11	150
40	165	140	105	81	40	4	19	16	2	131.5	70	10	14	240
50	178	155	120	96	50	4	19	16	2	145.0	70	10	17	250
65	190	175	140	116	65	4	19	18	2	166.0	102	12	17	250
80	203	185	150	126	80	8	19	18	2	190.6	102	12	22	400
100	229	210	175	151	100	8	19	18	2	209.7	102	12	22	400
150	394	280	240	212	150	8	23	22	2	268.7	125	13	27	600

Add:No.87-89,Mingyuan North Avenue, Economic Development Zone, Yongkang,Zhejiang Province,China  
 Tel:0086-579-8715288 0086-579-8725688 Fax:0086-579-87151442  
 E-mail:cnyvc@cnyvc.com yu@cnyvc.com Http:www.yongyuanvalve.com